

SRE06 ON/OFF THERMOSTAT

DESCRIPTION

SRE06 series on/off thermostat is mainly used in central air-conditioning heating and cooling system. It works with TSC series temperature sensor. It provides temperature control for central air-conditioning fan coil cooling / heating motorized valve or other electric actuator by the control signal which produced by comparison of actual tested ambient temperature and setting temperature.



CHARACTERISTICS

- Power surge and instant pulse protection.
- LCD showing ambient temperature, state and air volume.
- With system switch and fan speed switch.
- Built-in or external long-distance temperature sensitive element (NTC thermistor).
- With ABS fireproof plastic, in compliance with UL-94V0 standard.
- With flexible installation and convenient wiring.

TECHNICAL DATA

PRODUCT NAME	SRE06A (Heat/Cool) SRE06B (Cool Only)		SRE06C	
	2-PIPE		4-PIPE	
POWER SUPPLY	AC24V	AC220V/230V	AC24V	AC220V/230V
OUTPUT	AC24V 1A	AC220V/230V 1A	AC24V 1A	AC220V/230V 1A
POWER CONSUMPTION	0.6VA (without load)	5VA (without load)	0.6VA (without load)	5VA (without load)
FAN VOLTAGE	AC24V (2A)	AC220V/230V(2A)	AC24V (2A)	AC220V/230V(2A)
CONTROL PRECISION	±0.5°C (±1°F)			
CONTROL RANGE	10°C ~ 30°C or 50°F ~ 86°F			
SENSITIVE ELEMENT	NTC thermistor 10kΩ (when at 25°C/77°F)			
DISPLAY PRECISION	0.2°C / 1°F			
WORKING TEMPERATURE	0 ~ 55 °C/32 °F ~131 °F			
STORAGE TEMPERATURE	-10 ~ 60 °C/14 °F ~140 °F			
AMBIENT HUMIDITY	Max. 90% RH no condensation			

INSTRUCTION

1. **Cool/heat shift:** When the thermostat is used for 2-pipe application, move the power supply switch to “❄️”, the system will enter into cooling state, the LCD will show the cooling state symbol “❄️”. Move the switch to “🔥”, the system will enter into heating state, the LCD will show the heating state symbol “🔥”. Move the switch to “●”, the LCD will be shut off, and then the system will be shut off, too. When it is used for 4-pipe application, move the power supply switch to “ON” position, the system will be powered on and start to work, the cool/heat state will shift automatically according to the ambient temperature and setting temperature, and output control signal to control corresponding actuator. Move the power supply switch to “OFF” position, the LCD will be shut off and then the system will be shut off, too.
2. **Built-in/external sensor:** When built-in NTC thermistor is used, the jumper J3 should be put to “Int” position. If the external NTC sensor is used, the wire of the external sensor should be connected with terminal Rx, and the jumper J3 should be put to “Ext” position.
3. **Fan:** When the thermostat is in cooling or heating state, move the fan switch 🌀-🌀-🌀, the LCD will display corresponding air volume symbol. The terminals will output power and provide operating power supply for the fan. If the thermostat isn't connected to the fan, only 🌀 or 🌀 can be shown on

the LCD. The symbol  can only be shown when the thermostat is connected to fan completely and correctly.

4. **Temperature setting:** When user presses Δ (increase) / ∇ (decrease) button, LCD display temperature setting will show increase or decrease accordingly (Default value is 25°C/77 °F). For centigrade calculation, the increase/decrease rate is 1°C, the adjusting range is 10~30°C; for Fahrenheit calculation, the increase/decrease rate is 1°F, the adjusting range is 50~86°F. When user stops pressing the button for over 5 seconds, the thermostat will change the setting temperature data in its memory, and save the updating data. The LCD will show the ambient temperature. (You can choose the initialization setting point as 22°C/72°F, 23°C/74°F or 25°C/77 °F.)
5. The temperature range shown on the LCD is 0°C ~ 40°C or 32 °F ~ 99 °F.

WIRING DIAGRAM

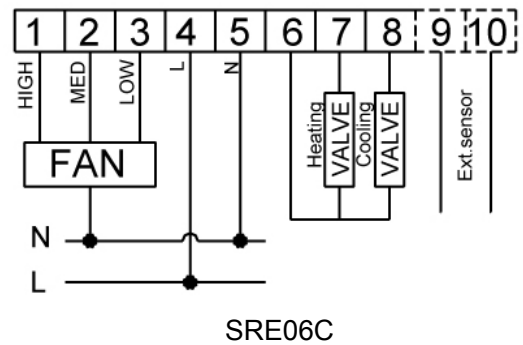
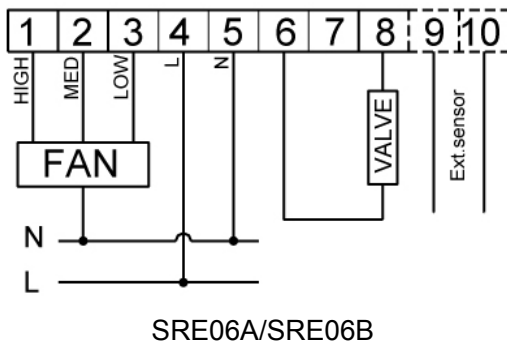

INSTALLATION DIAGRAM

